

Haus B: Marmorì Turm
Gewerbefläche B2.01.1C

Sandäckerstrasse 1a, 8957 Spreitenbach

Etage 1. Obergeschoss
Fläche 128.2 m²
Raumhöhe 2.28 m

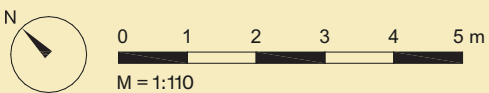
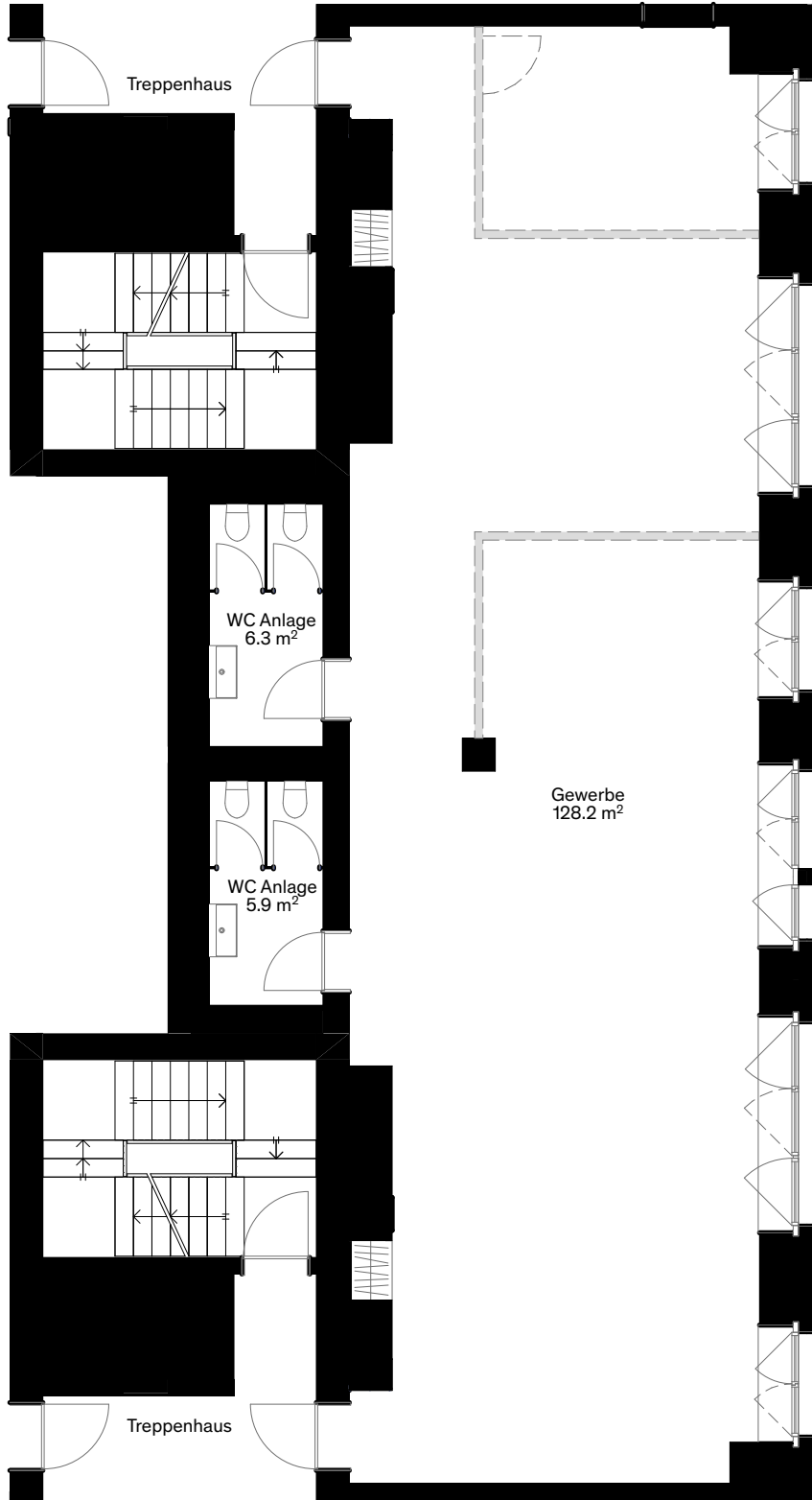
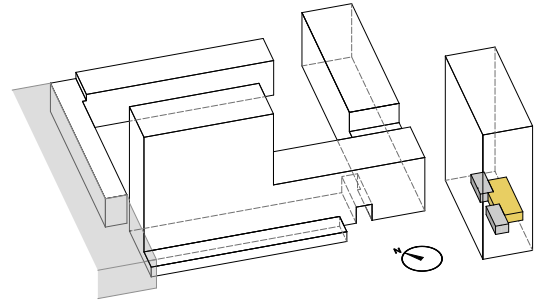

Intercity
Vermarktung